

MR3230

V_{BR} : 30 Volts
I_o : 32 Amperes

FEATURES :

- * Avalanche Voltage 38 to 42 Volts
- * High Power capability
- * Increased Capacity by Parallel Operation
- * Pb / RoHS Free

MECHANICAL DATA :

- * Case : Molded plastic
- * Epoxy : UL94V-O rate flame retardant
- * Polarity : Cathode polarity band
- * Mounting position : Any
- * Weight : 2.69 grams

AUTOMOTIVE TRANSIENT SUPPRESSOR DIODE

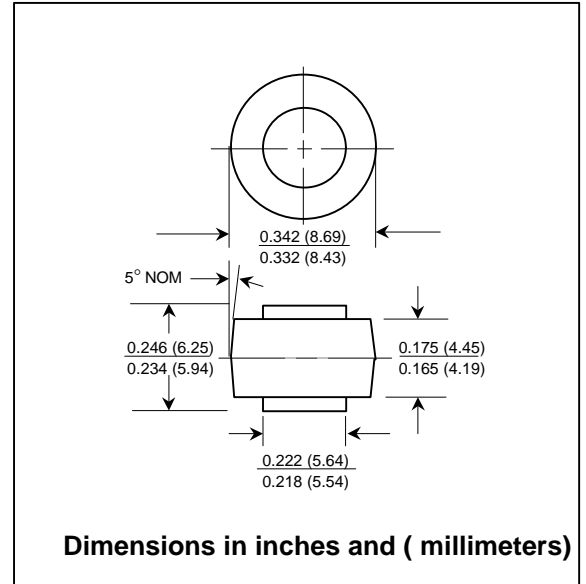

MAXIMUM RATINGS AND ELECTRICAL CHARACTERISTICS

Rating at 25 °C ambient temperature unless otherwise specified.
 Single phase, half wave, 60 Hz, resistive or inductive load.
 For capacitive load, derate current by 20%.

RATING	SYMBOL	VALUE	UNIT
Maximum Working Peak Reverse Voltage	V _{RWM}	30	V
Maximum DC Blocking Voltage	V _R	30	V
Minimum Breakdown Voltage (I _R = 100 mA, T _c = 25°C) (1)	V _{BR(min)}	38	V
Maximum Breakdown Voltage (I _R = 100 mA, T _c = 25°C) (1)	V _{BR(max)}	42	V
Maximum Average Rectified Forward Current (Single Phase, Resistive Load, 60 Hz, T _c = 150 °C)	I _{F(AV)}	32	A
Maximum Repetitive Peak Reverse Surge Current (Time Constant = 10 ms, Duty Cycle ≤ 1%, T _c = 25 °C)	I _{RSM}	77	A
Maximum Instantaneous Forward Voltage (I _F = 100 A , T _c = 150 °C) (1)	V _F	1.1	V
Maximum Reverse Current (V _R = 30 V, T _c = 25 °C)	I _R	1.0	μA
Maximum Reverse Current (V _R = 30 V, T _c = 150 °C)	I _R	500	μA
Typical Thermal Resistance Junction to Case	R _{θJC}	0.8	°C/W
Junction Temperature Range	T _J	- 65 to + 175	°C
Storage Temperature Range	T _{STG}	- 65 to + 175	°C

Note : (1) Pulse Test : Pulse Width ≤ 300μs, Duty Cycle ≤ 2%.