

RB521G-30

SCHOTTKY BARRIER DIODE

PRV : 30 Volts
I_o : 100 mA

FEATURES :

- * Small surface mounting type
- * High reliability
- * Pb / RoHS Free

APPLICATIONS :

- * Rectifying small power application

MECHANICAL DATA :

- * Lead finish : 100% Matte Sn (Tin)
- * Mounting position : Any
- * Qualified max reflow temperature : 260 °C

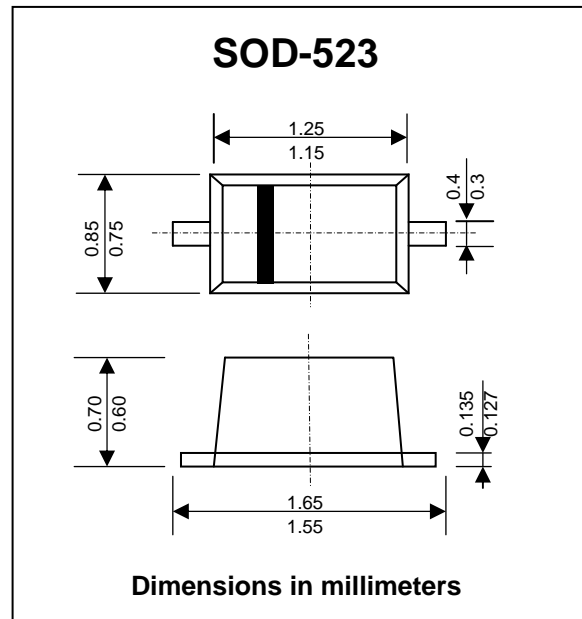

Maximum Ratings and Thermal Characteristics (T_a = 25 °C)

Parameter	Symbol	VALUE	Unit
Maximum DC Reverse Voltage	V _R	30	V
Average Rectified Forward Current	I _o	100	mA
Peak Forward Surge Current (60 Hz for 1 Cyc.)	I _{FSM}	1.0	A
Junction Temperature	T _J	125	°C
Storage temperature range	T _{STG}	-40 to + 125	°C

Electrical Characteristics (T_a = 25 °C)

Parameter	Symbol	Test Condition	Min	Typ	Max	Unit
Reverse Current	I _R	V _R = 10 V	-	-	10	µA
Forward Voltage	V _F	I _F = 10 mA	-	-	0.35	V

RATING AND CHARACTERISTIC CURVES (RB521G-30)

FIG.1 - DERATING CURVE

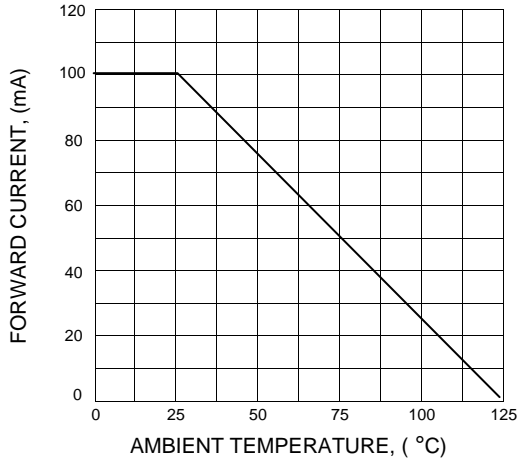

FIG.2 - CAPACITANCE BETWEEN TERMINALS CHARACTERISTICS

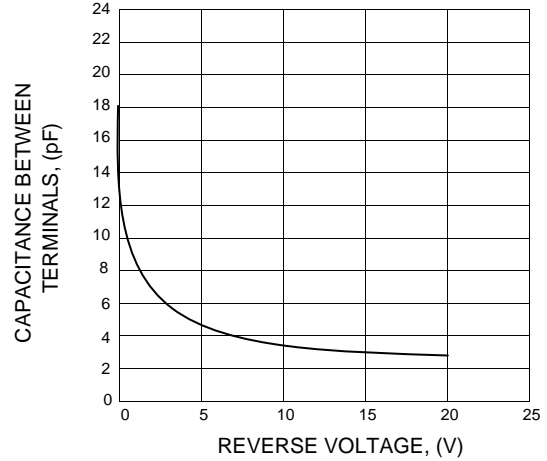

FIG.3 - TYPICAL FORWARD CHARACTERISTICS

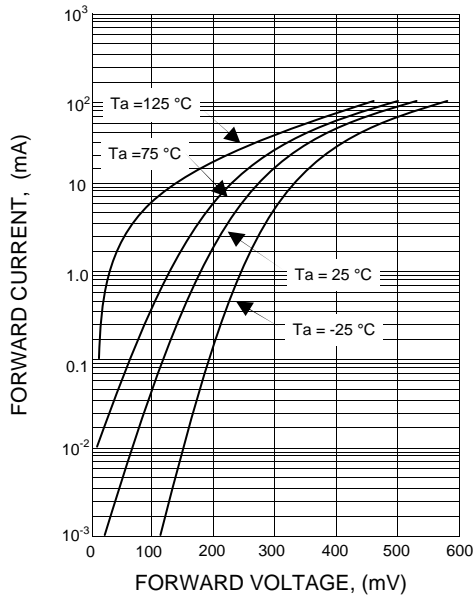

FIG. 4 - TYPICAL REVERSE CHARACTERISTICS

