

# SK22 - SK2B

# SURFACE MOUNT SCHOTTKY BARRIER RECTIFIERS

**PRV : 20 - 100 Volts**

**I<sub>o</sub> : 2.0 Amperes**

**FEATURES :**

- \* High current capability
- \* High surge current capability
- \* High reliability
- \* High efficiency
- \* Low power loss
- \* Low cost
- \* Low forward voltage drop
- \* Pb / RoHS Free

**MECHANICAL DATA :**

- \* Case : SMB Molded plastic
- \* Epoxy : UL94V-0 rate flame retardant
- \* Lead : Lead Formed for Surface Mount
- \* Polarity : Color band denotes cathode end
- \* Mounting position : Any
- \* Weight : 0.1079 gram

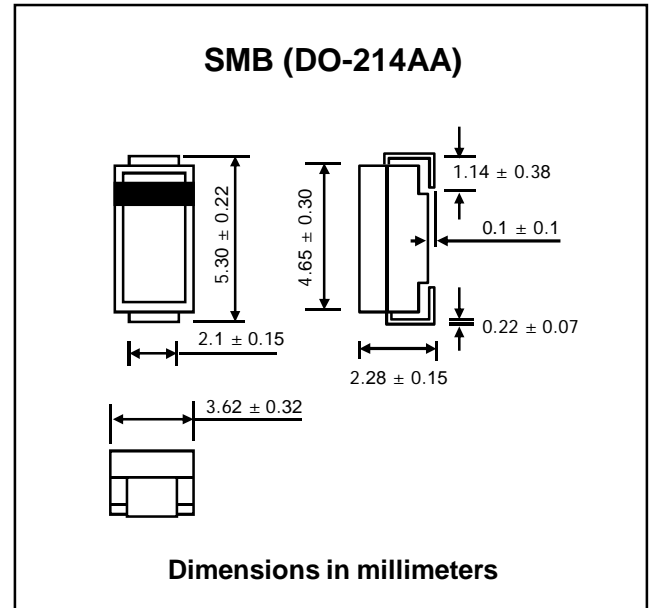

**MAXIMUM RATINGS AND ELECTRICAL CHARACTERISTICS**

Rating at 25 °C ambient temperature unless otherwise specified.  
Single phase, half wave, 60 Hz, resistive or inductive load.  
For capacitive load, derate current by 20%.

RATING	SYMBOL	SK 22	SK 23	SK 24	SK 25	SK 26	SK 27	SK 28	SK 29	SK 2B	UNIT
Maximum Recurrent Peak Reverse Voltage	V <sub>RRM</sub>	20	30	40	50	60	70	80	90	100	V
Maximum RMS Voltage	V <sub>RMS</sub>	14	21	28	35	42	49	56	63	70	V
Maximum DC Blocking Voltage	V <sub>DC</sub>	20	30	40	50	60	70	80	90	100	V
Maximum Average Forward Current See Fig.1	I <sub>F(AV)</sub>	2.0									A
Maximum Peak Forward Surge Current, 8.3ms single half sine wave superimposed on rated load (JEDEC Method)	I <sub>FSM</sub>	60									A
Maximum Forward Voltage at I <sub>F</sub> = 2.0 A. (Note 1)	V <sub>F</sub>	0.5			0.74			0.79			V
Maximum Reverse Current at Rated DC Blocking Voltage (Note 1)	I <sub>R</sub>	0.5									mA
Junction Temperature Range	T <sub>J</sub>	- 65 to + 125			- 65 to + 150						°C
Storage Temperature Range	T <sub>STG</sub>	- 65 to + 150									°C

**Note :**

(1) Pulse Test : Pulse Width = 300 μs, Duty Cycle = 2%.

**RATING AND CHARACTERISTIC CURVES ( SK22 - SK2B )**

**FIG.1 - FORWARD CURRENT DERATING CURVE**

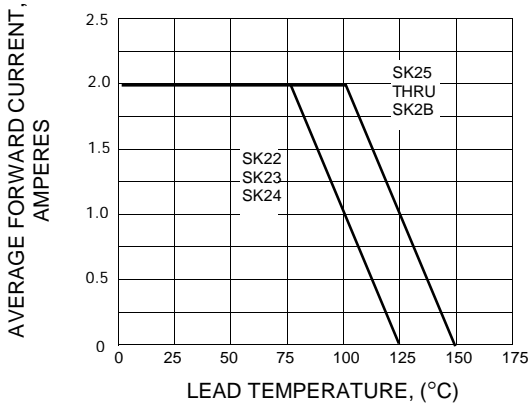

**FIG.2 - MAXIMUM NON-REPETITIVE PEAK FORWARD SURGE CURRENT**

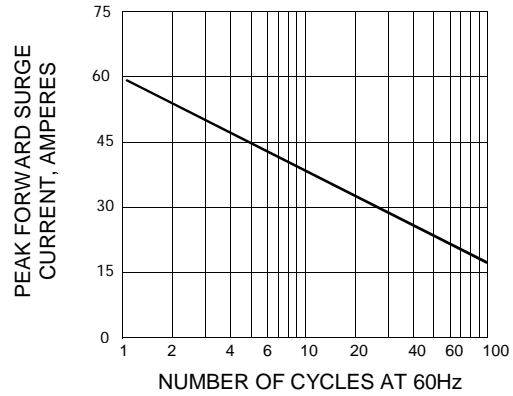

**FIG.3 - TYPICAL FORWARD CHARACTERISTICS**

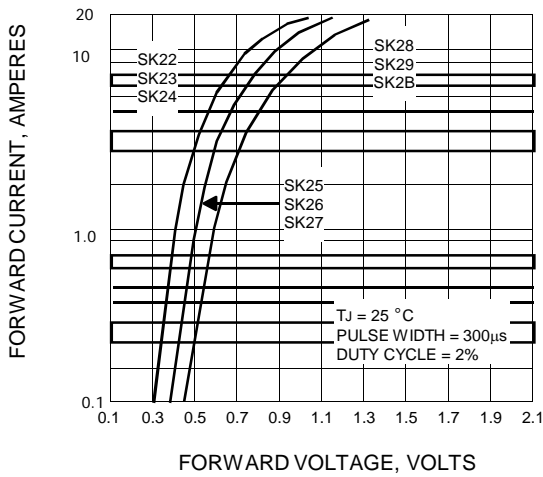

**FIG.4 - TYPICAL REVERSE CHARACTERISTICS**

