

MBR4035PT SERIES

PRV : 35~45 Volts
Io : 40 Amperes

FEATURES :

- * High current capability
- * Low power loss, high efficiency
- * High surge capacity
- * **Pb / RoHS Free**

MECHANICAL DATA :

- * Case : TO-247AD Molded plastic
- * Polarity : As marked on the body
- * Mounting position : Any
- * Weight : 5.6 grams

SCHOTTKY BARRIER RECTIFIER DIODE

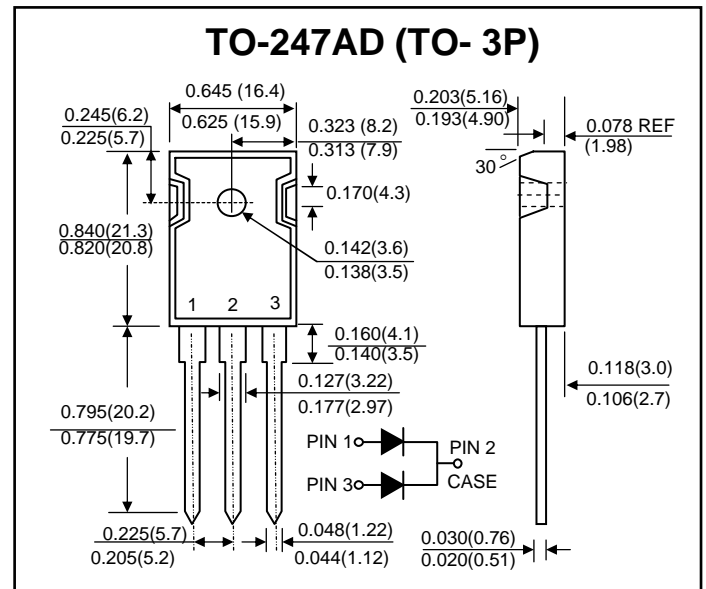

MAXIMUM RATINGS AND ELECTRICAL CHARACTERISTICS

Rating at 25 °C ambient temperature unless otherwise specific.

Resistive or inductive load

For capacitive load, derate current by 20%.

RATINGS	SYMBOL	MBR4035PT	MBR4045PT	UNIT
Maximum Recurrent Peak Reverse Voltage	V_{RRM}	35	45	V
Maximum Working Peak Reverse Voltage	V_{RWM}	35	45	V
Maximum DC Blocking Voltage	V_{DC}	35	45	V
Maximum Average Forward Rectified Current at $T_C=125\text{ }^\circ\text{C}$	$I_{(AV)}$	40		A
Peak Forward Surg Current, 8.3 ms single half sine-wave superimposed on rated load (JEDEC Method)	I_{FSM}	400		A
Maximum Instantaneous Forward Voltage per leg $I_F = 20\text{ A}, T_C = 25\text{ }^\circ\text{C}$ (Note 2) $I_F = 20\text{ A}, T_C = 125\text{ }^\circ\text{C}$	V_F	0.7	0.6	V
Maximum Average Reverse Current at $T_C = 25\text{ }^\circ\text{C}$ Rate Peak Reverse Voltage (Note3) $T_C = 100\text{ }^\circ\text{C}$	I_R	10	100	mA
Typical Thermal Resistance (Note 1)	$R_{\theta JC}$	1.4		$^\circ\text{C/W}$
Maximum Operation Temperature Range	T_C	-65 to + 150		$^\circ\text{C}$
Maximum Storage Temperature Range	T_{STG}	-65 to + 150		$^\circ\text{C}$

Notes :

- (1) Thermal Resistance from Junction to Case.
- (2) 300 μs Pulse Width , 2% Duty Factor.
- (3) 2.0 μs Pulse Width, $f = 1.0\text{ KHz}$

RATING AND CHARACTERISTIC CURVES (MBR4035PT ~ 40PT)

FIG.1 - FORWARD CURRENT DERATING CURVE

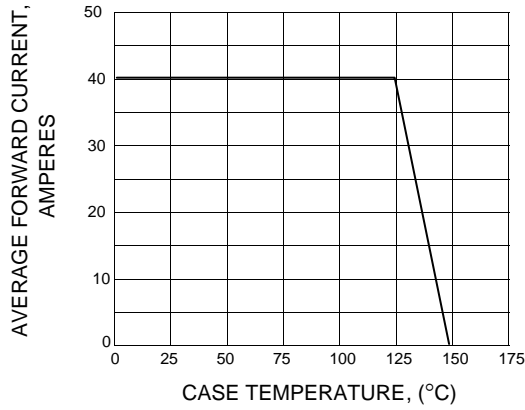

FIG.2 - MAXIMUM NON-REPETITIVE PEAK FORWARD SURGE CURRENT PER LEG

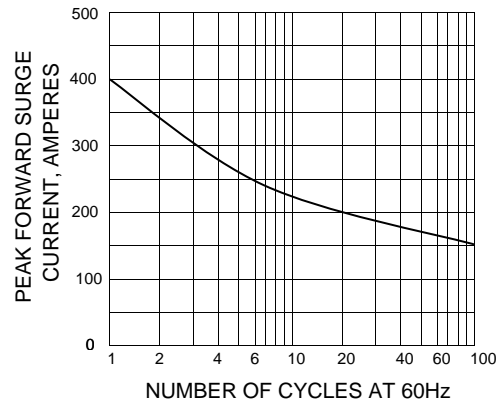

FIG.3 - TYPICAL INSTANTANEOUS FORWARD CHARACTERISTICS PER LEG

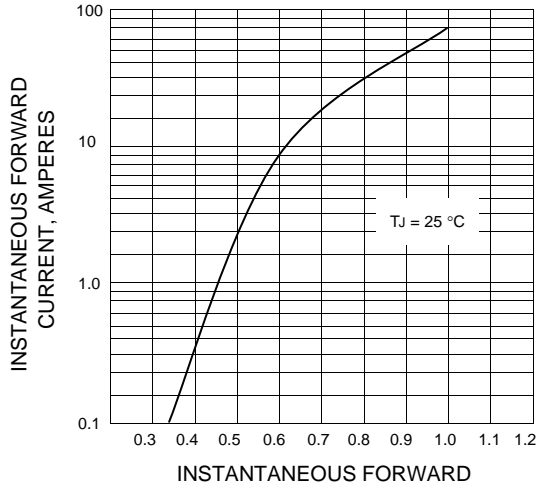

FIG.4 - MAXIMUM REVERSE CHARACTERISTICS PER LEG

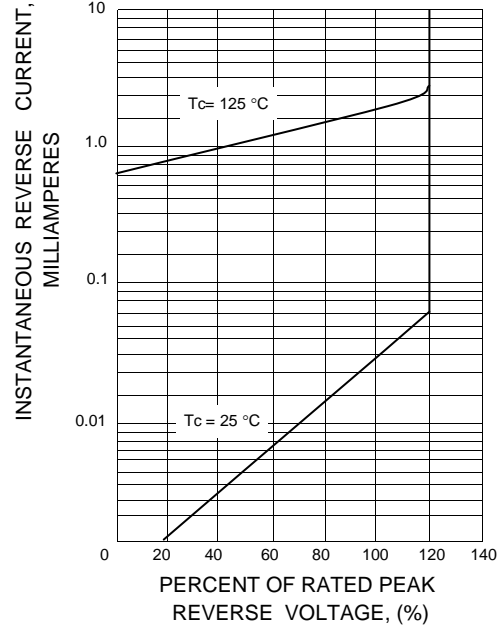

FIG.5 - TYPICAL JUNCTION CAPACITANCE PER ELEMENT

